



Overcoming the Uncanny Valley Theory in Digital Characters Based on Human Attitudes

Laja Uggah, L.* and Manaf, A.A.

Faculty of Creative and Applied Arts, Universiti Malaysia Sarawak, 94300 Kota Samarahan, Kuching, Sarawak, Malaysia

ABSTRACT

The uncanny valley theory is an idea pioneered by Masahiro Mori in 1970 in relation to the psychological effects of lifelike robotics (Mori, 1970). The uncanny valley is a phenomenon that occurs in animation and robotic, wherein things that look extremely similar to the human face, but with slight differences from the natural appearance or the natural movements and expressions of humans, that are found to be disturbing, uncanny, and revolting (Mewes & Heloir, 2009). This study aimed to accomplish three goals: 1) analysing the participants' attitudes towards digital characters based on a series of validated semantic differential questionnaires; 2) developing a conceptual model focusing on overcoming the uncanny valley theory in computer generated digital characters based on empirical findings; and 3) validating the theoretical model by providing specific guidelines for overcoming the uncanny valley theory by avoiding negative human attitude responses. Based on results from 229 participants, this study examined the key factors of digital characters from games and movies which caused uncanny responses from the participants based on their attitudes. The structural model indicates that digital characters' facial expressions have the strongest influence on the participants' perceived humanness, followed by the stimulus's physical movements. Meanwhile, the digital characters' animated hair has the next strongest influence on the participants' familiarity, followed by its facial expression.

Keywords: 3D Animation Perceived Humanness, Psychology, Stylized Animation, Uncanny Valley Indices

ARTICLE INFO

Article history:

Received: 15 December 2014

Accepted: 22 April 2015

E-mail addresses:

louislaja83@gmail.com/lu1z83@yahoo.com (Laja Uggah, L.),
amaazaini@faca.unimas.my (Manaf, A.A.)

* Corresponding author

INTRODUCTION

The uncanny valley theory is an idea pioneered by Masahiro Mori in 1970 in relation to the psychological effects of lifelike robotics (Mori, 1970). The name

the uncanny valley refers to the graph comparing human likeness and familiarity; familiarity increases as human likeness increases to a certain point, at which it takes a swift dive to the negative levels of familiarity when the likeness is extremely similar and yet not similar enough; familiarity then rises again as the likeness increases again, approaching the appearance of a natural human face (Mori, 1970). The key issues that need to be addressed in this study are the lack of studies in relation to moving and talking realistic digital characters based on participants attitudes' that have caused studios, designers and animators to opt for stylised digital characters so as to avoid negative emotional responses from viewers. The uncanny valley effect has also caused negative responses from audiences towards realistic but emotionless and lifeless digital characters such as Final Fantasy, Beowulf and Polar Express, which have been an issue for production companies for the past few decades (Segaya & Nakashima, 2007). This study focused on developing a conceptual model focusing on overcoming the uncanny valley effect in computer generated digital characters based on empirical findings and validating the theoretical model by providing specific guidelines on overcoming the uncanny valley theory by avoiding negative human attitude responses.

RELEVANT RESEARCH

In attempting to prove or disprove the uncanny valley theory, many researchers

have developed specific criticisms of the original uncanny valley, as expounded by Mori. In a study by Tinwell *et al.* (2011), for example, participants were shown videos of multiple characters and asked to rate them in terms of human-likeness and familiarity. The researchers in that study accepted Masahiro Mori's terminology (as it is commonly translated into English) of "familiarity" as a factor that is contrary to a sense of eeriness or discomfort with characters in the uncanny valley (Mori, 1970) despite the criticism of some that "familiar" and "eerie" are not self-evident antonyms or ambivalence about what exactly the chart of "familiarity" is meant to describe (Ho *et al.*, 2008). Results of the study by Tinwell, Grimshaw, and Williams did not reveal an uncanny valley at all; in fact, the characters by and large increase their familiarity scores as they increase their human verisimilitude; the only dramatic exception was the character Mario from Mario Bros., who is emphatically non-human but received a very high score on "familiarity" possibly because he is a famous character in video games (Tinwell *et al.*, 2011). However, the researchers themselves interpreted a valley as existing between the characters of Mario and Lara Croft, rather than seeing these two famous characters as unexpected spikes in the "familiarity" index compared to a larger number of non-famous characters. Tinwell, Grimshaw, and Williams' study would have been stronger, as they acknowledged, if they had included solely non-famous characters or had gathered data about

whether their respondents were already familiar with the characters in order to control for this particular variable.

Another criticism of the uncanny valley theory that animators have expressed is the theoretical closeness between uncanny realism and pleasing realism. This criticism is based on the fact that many animators choose to make their animated characters deliberately stylised in order to convey to the audience that they are not attempting to create a character that looks lifelike, and thus, paradoxically, to create a character that the audience can relate to (Geller, 2008). In this criticism, the problem is not that the uncanny valley is not supposed to exist, but that it is not placed accurately with regards to actual human responses, at least not based upon the professional experience of certain animators such as Kenn McDonald, who worked on both *The Polar Express* and *Beowulf* for Sony Pictures (Geller, 2008). Of course, this criticism is in essence similar to Mori's own recommendation that human-like items be prevented from being *too* close to human appearance in order to avoid falling into the uncanny valley (Mori, 1970): stylising the animations so that the audience is not distracted or turned off by wondering whether the characters on screen are in fact live action or not, or finding the characters to be eerie.

METHODS

In order to understand the effects of the uncanny valley on the participants' attitude towards digital animated characters,

this study investigated the participants' attitudes towards digital stimuli. This study employed the quantitative approach based on semantic differential questionnaires. For the purpose of this research, the Perceived Humanness and Familiarity indices were developed by Ho and Macdorman (2011), while the other indices were modified and based on Ho and Macdorman's Uncanny indices. This study was conducted in Yahos Training Centre's conference hall. This venue was selected because it was the most convenient and cost effective for the organiser. The sampling method used for this study was the systematic sampling method, as we preferred participants with moderate knowledge of digital characters, either in games or movies. The participants consisted of gamers, university students, moviegoers and creative professionals, who aged between 18 and 35 years at the time of this study. The participants were invited through email, Facebook and telephone calls. The participants were requested to rate all the stimuli based on the questionnaires. Responses were saved in an Excel file, which was attached to the e-mail. The total number of participants was initially proposed at 300, but only 229 responded to the invitation to participate in the survey.

The five stimuli selected for this study consisted of female digital characters such as Ellie from "The Last of Us", Madison Paige from "Heavy Rain", Elastigirl from "The Incredibles", Digital Ellie by Image Metrics and finally the control stimulus, which was represented by a real person. In

order to avoid response bias, only female digital characters were chosen in this study. These characters are generally the heroines in the movies or games so as to enable the researchers to study the participants' attitudes towards the digital characters.

STRUCTURAL EQUATION MODELLING (RESULTS OF MEASUREMENT VALIDITY)

Principal component analysis was used because it helps to reduce the dimension of the data set by reducing the data into basic components. The Kaiser-Meyer-Olkin measure of sampling adequacy is .934, which is above the recommended value of .6, while the Bartlett's test of sphericity is significant ($p < .05$). The communalities for all the indices are above 0.3, which concluded that all the items shared some common variance with other items. Based on the Pattern matrix table, all subscales are each loaded into its own factor, as follows: Facial, Rig, Hair, Eyes, Lighting, Lip Sync. All the subscales loaded in the range of 0.65 to 0.97. The construct reliability and validity of the measurement model of this study were also calculated using SPSS software to check for its internal consistency. Construct validity test, which is essential to the perceived overall validity of the measurements, was divided into two subtypes: convergent validity and discriminant validity. Convergent validity tests determine whether the factors that are expected to be related are actually related, while discriminant validity test determines whether the factors which are supposed

to be unrelated are actually unrelated. To test the factors convergent validity, we refer to the Pattern Matrix extracted from the SPSS output. Each of the eight factors achieved an average load of above 0.7, which indicated that the factors are related. For the discriminant validity tests, the Pattern Matrix indicated that there are no cross loadings among the factors. The component correlation matrix revealed that none of the factors had a correlation of greater than 0.7, indicating that there are no correlations between the factors. These discriminant validity tests concluded that each factor is unrelated which each other. Cronbach Alpha test is crucial to determine the validity of the study's psychometric test. The reliability analysis in the table below reveals that all the factors achieved an average Cronbach Alpha above 0.7, which is considered good in terms of internal consistency; therefore, we decided to maintain all the subscale indices for all the factors.

TABLE 1
Reliability Analysis

Cronbach's Alpha	N of Items	Factor
.887	3	Lip Sync
.881	3	Texture
.876	3	Hair
.846	3	Humanness
.799	3	Eyes
.856	3	Familiarity
.849	3	Movement
.758	3	Facial

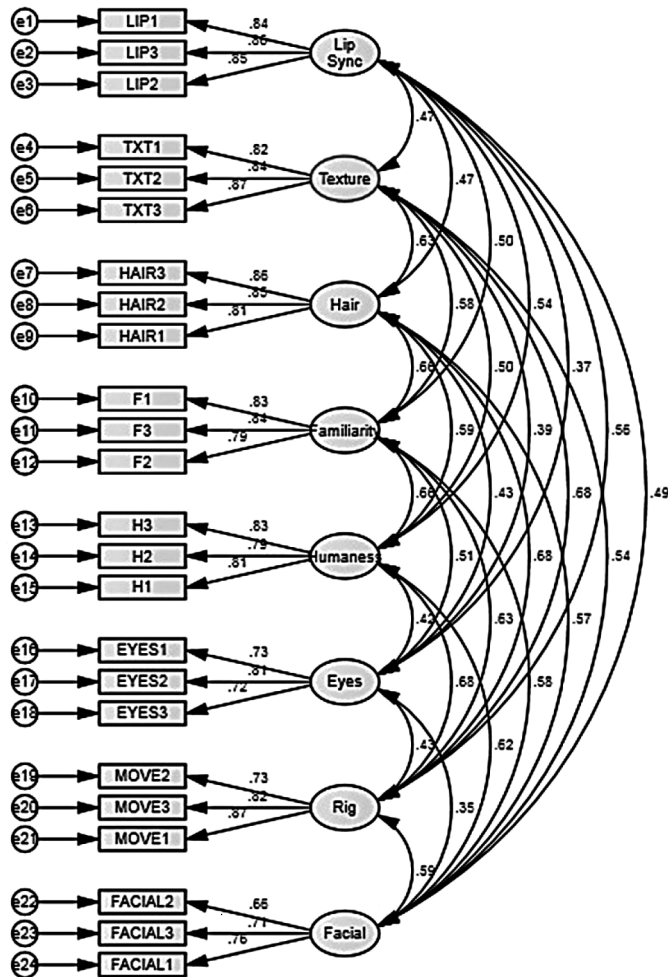

Fig. 1: Final Measurement Model

CONFIRMATORY FACTOR ANALYSIS

The first step in a Confirmatory Factor Analysis (CFA) is to develop a decent measurement model based on the pattern matrix obtained from SPSS. By using the Pattern Matrix plugins for AMOS, a decent measurement model (see Fig.1) was obtained.

The next step of the confirmatory factor analysis is the analysis of measurement

invariance of latent constructs. Van De Schoot *et al.* (2012) stated that analysis of measurement invariance is important in order to determine where the latent variables are valid across groups. In this study, the groups were divided into 3 based on the stimuli, which are, realistic, stylized and all groups. The figure below shows that at least one of the loadings is non-significant.

The final measurement model of exogenous and endogenous was tested by assessing the fit indices. The CMIN/df for this model was 1.36, indicating a model fit. The comparative fit index (CFI) was 0.991 and the goodness of fit index (GFI) was 0.965. The adjusted goodness of fit index (AGFI) was 0.953. The mean square error of approximation (RMSEA) was 0.013. Meanwhile, all CFI, GFI, AGFI and RMSEA for this measurement model met the criteria for a model fit (Hu & Bentler, 1999). Then, the average variance of extracted (AVE) values were analysed for all the items. The AVE for all the items ranged from 0.51 to 0.72, which is above the cut-off value of 0.5. The CFA analysis confirmed that the data fit the hypothesised measurement model.

RESULTS AND FINDINGS

Our descriptive analysis revealed that in terms of facial expression, the control stimulus achieved the highest ratings with an average rating of 4.0. This was followed by stimuli 4 (Digital Emily), with the mean rating of 3.93. Stimuli 2 (Madison Paige) achieved the lowest mean rating of 2.79. In terms of physical movements and rigging, the control stimulus once again achieved the highest mean rating of 4.14, followed by Digital Emily with 4.05 and stimulus 3 with 3.76. Stimulus 2 was rated the lowest with a mean rating of 2.6. Then, the participants rated the digital eyes with the control stimulus achieving the most desirable effect from the participants, with a mean rating of 4.03 followed in a distance

by stimulus 4 with a mean rating of 3.62. Madison Paige achieved the lowest mean rating of 2.86. For hair animations, Digital Emily surprisingly achieved better mean ratings than the control stimulus, with 4.6 and 4.46 mean ratings for the control stimulus. This was followed closely by stimulus 3 with a mean rating of 4.0. For lighting methods, stimulus 1, 3 and 4 were not significantly different from each other with the mean ratings of 4.5, 4.27 and 4.58, respectively. Stimulus 2 achieved the lowest with a mean rating of 2.92. Finally for the lip syncing factor, stimulus 1 achieved the highest rating with 4.7, followed by stimulus 4 with 4.02. Stimulus 3 and 5 were not significantly different from each other with the mean ratings of 3.97 and 3.77, respectively. Once again, Stimulus 2 achieved the lowest rating of 2.86.

This structural model shows how these factors affect the participants' attitudes towards digital characters. Our structural model achieved a good fit with CMIN/df of 1.365, RMSEA of 0.013, CFI of 0.991, GFI of 0.965 and AGFI of 0.953, which are based on Hu and Bentler (1999), who recommended that RMSEA should be <0.6 and CFI >0.9 , while Baumgartner and Hombur (1996) recommended that GFI and AGFI should be >0.9 . These show that our structural model has achieved a good fit.

In order to explore the relationship between the six factors and the participants' perceived humanness and familiarity, a structural equation model (SEM) was calculated. Based on the regression weight on the structural model based on all the

stimuli, lip syncing techniques had a non-significant effect on participants' familiarity towards the stimuli with ($r^2 = 0.089$, $p < 0.05$). Meanwhile, other factors such as lighting and physical movements also had non-significant effect on participants' familiarity with ($r^2 = 0.118$, $p < 0.05$) and ($r^2 = 0.184$, $p < 0.05$). The next factor, which is hair animation, had a moderate significant effect on familiarity ($r^2 = 0.275$, $p > 0.05$), while other factors such as digital eyes and facial animations had moderate significant effects on familiarity as well, with ($r^2 = 0.244$, $p > 0.05$) and ($r^2 = 0.252$, $p > 0.05$), respectively.

As for the participants' perceived humanness towards all the stimuli, factors such as physical movement and facial expression had high and significant effects on the participants' perceived humanness

with ($r^2 = 0.487$, $p > 0.05$) and ($r^2 = 0.366$, $p > 0.05$), respectively. Hair animation also had a low significant effect on the participants' perceived humanness ($r^2 = 0.137$, $p > 0.05$). Surprisingly, eyes and lighting had no significant effect on the participants' perceived humanness.

Based on the scatterplot data from SPSS, the participants' familiarity and perceived humanness had a positive and non-linear correlation. Evans (1996) suggested that $r = 0.8-1$ is a very strong value, while $0.6-7.9$ is strong. Meanwhile, the R values which are below 0.4 are considered weak. For familiarity and perceived humanness, an r-value of 0.737 was achieved, which is considered as strong. This correlation indicates that the more realistic the digital characters are, the more familiar they are perceived by audience.

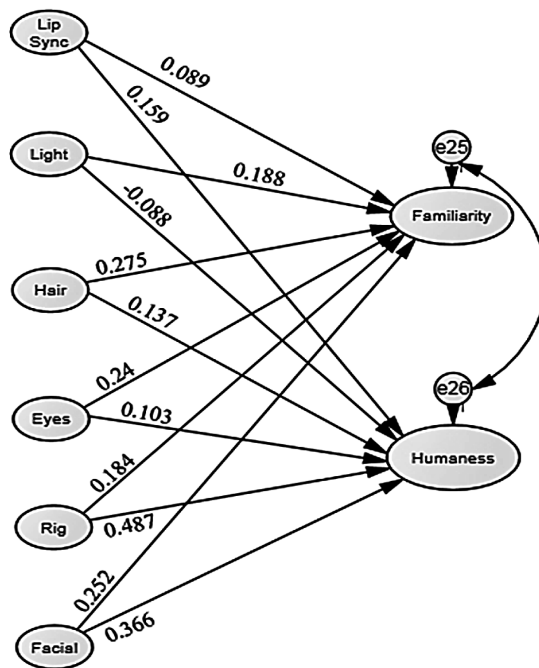

Fig.2: Structural Equation Model

DISCUSSION

This research focused on analysing participants' attitudes towards realistic and stylised digital characters in general and also developing a test the structural model, including six animation factors and participants' attitudes towards the stimuli and the effects on their perceived humanness and familiarity. Our research began by developing an initial measurement model to measure human attitudes' towards different types of digital characters developed by well-established animation studios. After validating the measurement model, we proceeded with our data collecting process, which comprised 229 participants from various backgrounds and ages. The mean analysis indicated that Digital Emily achieved the highest mean ratings among the digital stimuli in terms of facial expression, physical movements, hair animation, digital eyes, lighting and lip sync. The second phase of the study adopted the SEM method to test the hypothesised relationships between all the factors. The structural model revealed empirical evidence that the three factors had significant effects on participants' familiarity, which included digital hair, eyes and facial expressions. The factors with significant effects on participants' perceived humanness were lip sync, digital hair, physical movements and facial expression. Digital characters that included detailed digital hair, digital eyes and facial expressions were found to have been perceived to be less eerie and uncanny by the audiences, thus

overcoming the uncanny valley theory on those characters. Increasing realism in digital characters would require animators to add more details in lip sync movements, physical movements, digital hair and facial expressions of the digital characters.

IMPLICATIONS

The previous research by Macdorman, Green Ho and Kock (2008) indicated that realistic digital characters were not necessary eerie, which is against Mori's (1970) theory of the uncanny valley. Similarly, Seyama and Nagayama (2007) also stated that audience will not be repulsed by artificiality as it approaches lifelikeness, as long as the level of artificiality is uniform and there are no jarring elements. Their conclusion is supported by our findings which indicated that highly realistic digital character such as Digital Emily is able to achieve high ratings in terms of familiarity and realism. Tinwell, Grimshaw and Williams (2011) posited that the existence of an uncanny wall, rather than an uncanny valley, suggests that it is simply impossible for artificial methods to successfully approach human likeness to the point that people cannot tell the difference between the artificial and the real. Our findings have proven otherwise with the ratings of Digital Emily and the control stimulus as not significantly different from each other in terms of perceived humanness. Other theoretical implications of our findings also indicated that all the other factors, besides digital eyes such as facial expression, hair animation, physical animation and

lip syncing, are significant in causing the uncanny valley effects among human audience. In terms of methodological implications, our study has developed a validated measurement model which is based on six key factors in animations measured by the participants' attitudes in a semantic differential scale, which is a modified version of Ho and Macdorman's (2011) uncanny indices measurement model. This measurement model can be used by students or animators to measure the effectiveness of their digital characters based on the participants' attitudes and familiarity.

CONCLUSION

Based on the structural equation model (Fig.2), it can be concluded that students or animators should put more emphasis on the digital characters' facial expressions and physical movements so as to achieve desirable realism as both factors (facial expressions and physical movements) have high significant effects, with ($r^2 = 0.487$; $p > 0.05$) and ($r^2 = 0.366$; $p > 0.05$) respectively, on the participants' perceived humanness. If animators do not require a lot of realism (e.g., by using stylised animation), they should focus on the characters' hair animation and facial expressions, which were found to have significant effects on the participants' familiarity. Meanwhile, other factors such as digital eyes, modelling/animation and lighting manipulation should not be neglected. Thus, we proposed that animators and researchers who intend

to produce highly realistic animations emphasise on their characters' facial expression and physical movements, in addition to desirable hair animation and lip syncing to avoid the uncanny valley.

SIGNIFICANCE OF THE RESEARCH

This research has extended our knowledge in the creative industry, especially in animation, by providing empirical evidence on how various types of digital characters affect viewers' attitudes towards them. This research has also confirmed that the Digital Emily Project developed by Image Metrics is currently the most realistic digital character perceived by human audience and familiarity. This model can also be referred to by novice animators as a guideline for their animation production process in order to avoid any uncanny effect from audience. This model can be referred to by animators, while modelling realistic digital characters instead of avoiding it altogether and opting for stylised animation as sales demand for realistic digital characters are increasing especially in digital games.

FUTURE RESEARCH

Future research should focus more on types of digital characters as the stimuli to study participants' attitudes based on these digital characters. This will allow participants to compare more stimuli and allow them to make better judgement in terms of ratings. The current structural model is based on 5 stimuli, with one of the stimuli as the control stimulus. Besides that, future researchers should conduct

a survey on a dedicated website to allow more participants around the world to take part in the survey. Finally, interactive digital characters should be included as the stimuli for future research in order to study the interactions between digital characters and participants' emotions and attitudes.

REFERENCES

- Evans, J., S. B., & Over, D. E. (1996). *Rationality and reasoning*. Hove: Psychology Press.
- Geller, T. (2008). Overcoming the uncanny valley. *IEEE computer graphics and applications*, 28(4), 11-17. Retrieved from <http://people.cs.luc.edu/whonig/comp-388-488-robotics/course-materials/course-reading-materials/UncannyValleyGraphicsmcg2008040011.pdf>
- Ho, C. C., & MacDorman, K. F. (2010). Revisiting the uncanny valley theory: Developing and validating an alternative to the Godspeed indices. *Computers in Human Behavior*, 26(6), 1513-1517. Retrieved from <http://www.journals.elsevier.com/computers-in-human-behavior>.
- Ho, C.-C., MacDorman, K. F., & Promono, Z. D. (2008). Human emotion and the uncanny valley: A GLM, MDS, and Isomap analysis of robot video ratings. In *Proceedings of the 3rd ACM/IEEE international conference on human robot interaction*, pp. 169-176.
- Hu, L. T., & Bentler, P. M. (1999). Cutoff Criteria for Fit Indexes in Covariance Structure Analysis: Conventional Criteria Versus New Alternatives. *Structural Equation Modeling*, 6(1), 1-55.
- MacCallum, R. C., Browne, M. W., & Sugawara, H. M. (1996). Power Analysis and Determination of Sample Size for Covariance Structure Modelling. *Psychological Methods*, 1(2), 130-49.
- Mewes, D., & Heloir. (2009). *The Uncanny Valley*. Retrieved from http://embots.dfki.de/doc/seminar_ss09/writeup%20uncanny%20valley.pdf
- Mori, M. (1970). The uncanny valley. *Energy*, 7(4), 33-35.
- Seyama, J., & Nagayama, R. S. (2007). The uncanny valley: Effect of realism on the impression of artificial human faces. *Presence: Teleoperators and virtual environments*, 16(4), 337-351. doi:10.1162/pres.16.4.337
- Tinwell, A., Grimshaw, M., & Williams, A. (2011). The uncanny wall. *International journal of arts and technology*, 4(3), 326-341. doi:10.1504/IJART.2011.041485
- Van de Schoot, R., Lugtig, P., & Hox J. (2012). A checklist for testing measurement invariance. *European Journal of Developmental Psychology*, 9(4), 486-492.