

Attracting Factors of Retirement Village Migration: A Literature Review

Mohamad Naquiuddin Md Mansor^{1*}, Siti Noorsuriani Maon², Mumtaz Ahmad³ and Norzaidi Mohd Daud⁴

^{1,2,3} *Centre for Management and Administration Studies, Faculty of Business and Management, UiTM Selangor, 42300 Bandar Puncak Alam, Selangor, Malaysia*

⁴ *Office of Community of Research (Management Science), Bangunan Wawasan, UiTM Selangor, 40450 Shah Alam, Malaysia*

* ¹*naquiuddin@salam.uitm.edu.my (corresponding author)*

²*sitiinoor123@salam.uitm.edu.my*

³*mumtaz2627@salam.uitm.edu.my*

⁴*norza544@salam.uitm.edu.my*

ABSTRACT

Aging population remains a global phenomenon in this new millennium and is poised to become a major issue in developing countries. Malaysia is one of upper middle income country that is experiencing rapid aging of its population. Most of the time, aging population associated with abandonment by family and loneliness. As Malaysia's ageing population is keep increasing, the need for an environment for fellowship and social interaction while enjoying the support services and amenities is becoming critical for retirees. The present study aim to investigate the attracting factors associated with a retirement village migration. Based on the literature review, four attracting factors have been identified that are facilities, environment, lifestyle, and healthcare status. This study is in progress, thus the expected outcome will helps the government to develop a retirement village that suit with Malaysia culture and preferences.

Key Words: Attracting factors, Retirement village, Aging population

1. INTRODUCTION

Aging population is poised to become a major challenge to the health system as Malaysia progresses to becoming a developed nation by 2020. Malaysia's population is

expected to grow from 28.31 million in 2009 to about 33.4 million by the year 2020 (Department of Statistic, Malaysia 2016). According to the previous study that had been agreed by Beh & Yoong (2012), this phenomenon had lead Malaysia to turn into an aging country at 6.3% of its population consists of elderly people, which were over 60 years old and above in 2000 and predicted to increase at 9.9% in 2020. Due to the raising of aging population, it is important to perform this research so that it helps Malaysian society to plan their retirement and reduce down the essence of poverty during their post retirement period.

Most of the time, it is associated with abandonment by family, loneliness and in extreme cases destitution. This perception is expected to change soon as families become smaller and more time and effort are exacted from family members to cope with the rising cost of living. Younger people, having seen the amount of care their grandparents need at old age, are also concerned about their future with fewer siblings and even smaller families.

Even though demands of an aging population rise significantly, but the developers must consider whether the models in overseas are suitable and can be adopted in Malaysia. A developer who wants to develop retirement village needs to consider the Malaysian culture and stigma associated with sending the elderly to an old folks' home. Hence this study would like to identify the

attracting factors that will encourage Malaysian to stay retirement village.

2. LITERATURE REVIEW

2.1. Malaysia Population

In 2016, total population of Malaysia is estimated at 31.7 million persons, an increase of 0.5 million persons as compared to 31.2 million persons in 2015 with 1.5 per cent population growth rate for the same period. Table 1 shows proportion of

population by age groups from 2010 to 2016. There is major difference for 2016 as compared with the year 2010. Population in groups 0-14 years old decreased 3.1 percent at 2016 (24.5%) as compared to 2010 (27.6%). While for 15-64 years old age population, there is increased by 2.1 percent at 2016 as compared to 2010. Subsequently, population aged 65 years and above was also increased by 0.9 percent at the same period. The trend of these indicators is in line with the transition of age structure towards aging population of Malaysia.

Table 1: Population Composition by Age Group, Malaysia, 2010-2016

Age Group	2010	2011	2012	2013	2014	2015	2016
0-14 years	27.6%	26.9%	26.4%	26.0%	25.3%	24.9%	24.5%
15-64 years	67.3%	68.0%	68.3%	68.5%	69.0%	69.2%	69.4%
65 years and above	5.1%	5.1%	5.3%	5.5%	5.6%	5.8%	6.0%

Source: Department of Statistic, Malaysia (2016) and Health Informatics Centre (2014)

Therefore there is an urgency to prepare the nation for the eventuality as it takes more than a decade for social institutions to change. Strategic approaches need to be designed to avert the crisis of old age in Malaysia and at the same time addressing the needs of other sectors of the population.

2.2. Retirement Village

There is a number of housing options are available for older people, ranging from independent-living alternatives through high-level care (Jian et. al, 2014). The term of retirement village in the Australian context normally refers to a community that is independently living people, aged around 55 years and above with associated facilities (NSW Fair Trading, 2011). According to Saville-Smith (2011) retirement villages are typically marketed as a lifestyle choice in which retirees can have independent living in a managed facility.

According to Counsel (2014) retirement villages means a complex containing

residential premises that are predominantly or exclusively occupied, or intended to be predominantly or exclusively occupied, by retired people who have entered into village contracts with an operator of the complex.

In addition, retirement village provides people with independent accommodation in a community setting with shared facilities, and often lifestyle and social amenity. Retirement Village can be run by commercial operators for profit or by community organizations, such as religious or ethics associations (Parliamentary Library Research Service, 2012). In first world countries, retirement village are in actuality top notch and strictly monitor places where the elderly can be given the best care that money can buy, where children can rest well knowing that their parents are being well cared for.

The term retirement home in Malaysia is unfortunately highly misconstrued and misunderstood, as old folks homes. These homes for elderly who no one there to care for them anymore. Historically, Sri Seronok Retirement Village located in Cheras claimed as the first retirement village established in

Malaysia. This home was conceived by Soter Fernandez, a former Roman Catholic Archbishop of Kuala Lumpur offers an alternative housing option for active and independent senior citizens. Completed in 1988, this village consists of 30 linked units each comprising a living room, bedroom and kitchen built around a courtyard. However, it is an inaccurate concept to call it as a retirement village.

2.3. Attracting Factors

Research by Netten et. al (2011) state that the reasons for moving were classified as push or pull factors, relating to residents' previous circumstances or to the attractions of extra care. Gibler et. al. (2009) state that push factors such as loss of independence, loss of spouse and environmental stress encourage movement and pull factors such as retirement amenities, relocated friendship, successful relocation by friends and environmental amenities attract the elderly to migrate.

2.3.1 Facilities

Retirement village might be designed for people aged 65 years or older that offer a range of health, leisure and support services. Village may include recreational and medical facilities such as room for visiting doctors, nursing homes, medication or other allied health professionals. This is the right place to live by elderly people who seek for better lifestyle in the future.

2.3.2 Environment

The design of the environment must consider the declining visual, auditory, and kinaesthetic senses to maintain mobility, autonomy, independence, and well-being. Impaired hearing and vision need to be compensated by louder signals and increased lighting. Moreover, more resting places may also be required for older adults who have low stamina (Kerr, Rosenberg & Frank, 2012)

2.3.3 Lifestyle

Lifestyle is someone or group's way of living. It is a composite of motivation, needs, and wants and is influenced by factors such as culture, family, reference group, and social class. While active lifestyle refers to any physical activity in daily routine such as incorporates exercise, active transportation, recreational, household and occupational activities. An active lifestyle will decrease the risk of falls and delay functional limitations and mobility disability. This will ensure older adults to continue living independently for longer time. Retirement villages are specifically designed to cater to the lifestyle needs of people aged 65 years old and above. They generally provide accommodation units and common areas that promote and facilitate social interaction and support (Miskovski, Chenoweth, & Moore, 2015).

2.3.4 Healthcare Status

Older retirees are more likely to be pushed by poor health and mobility impairment. Past research has indicated declining physical health and mobility is the commonly reported reason for late-life relocation (National Seniors Productive Ageing Center, 2013). Michael & Anupam (2012) find out that older people moves are reflecting to their health status constraint. When deciding to move, a family-based decision process based on healthcare services and proximity to family become the influential factors. Furthermore, older adults are most likely to encourage relocation to a retirement village included provision for continuing health care needs, home maintenance support and the convenient location of facilities.

3. CONCEPTUAL FRAMEWORK

In this study, the independent variables are attracting factors that consist of facilities,

environment, lifestyle, and healthcare status. On the other hand, the dependent variable is migration decision to retirement village. The relationship between these two variables is shown in figure 1.

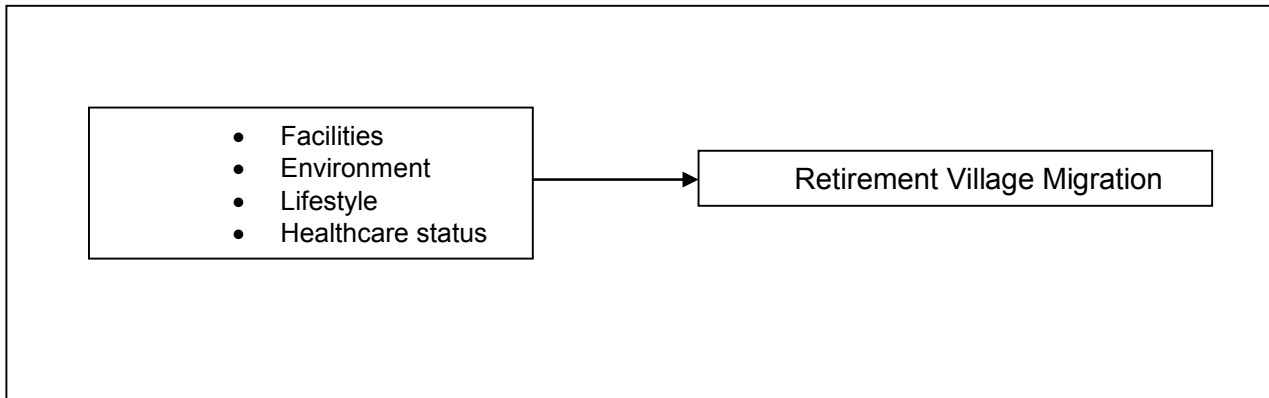

Figure 1: Conceptual Framework for Attracting Factors of Retirement Village Migration

4. CONCLUSION

Elderly mostly refuse to move to another place that might affect their comfortability. Unfortunately, because of health condition that need assistance for their daily life, such as for doing chores and need help for moving to elsewhere and at the same time they might need new environment that suitable for their age. Retirement village are relatively new form of housing to appear on the aging landscape and there is demand for this style of living by a small proportion of the older proportion. The demand might increase as the elderly suggests these places provide a viable alternative lifestyle to that in the broader community.

REFERENCES

Counsel, A. P. (2014). Retirement Villages Act 2012. Australia: Australian Capital Territory.
 Department Of Statistic, Malaysia (2016). Current Population Estimates, Malaysia, 2014-2016.
 Gibler, K. M., Manuel Casado-Díaz, J., Angeles Casado-Díaz, M. & Rodríguez, V.

(2009). Late Life Second Move Housing Choices of International Retiree Migrants, *International Journal of Housing Markets and Analysis*, 2(2), 190-210.
 Health Informatics Centre (2015). *Health Facts 2014*. Putrajaya: Planning and Development Divison, Ministry of Health Malaysia.
 Jian, Z., Bo. X., Barker, J. & Skitmore, M. (2014). Green Buildings for Greying People. *Facilities*, 32 (7/8), 365-381.
 Kerr, J., Rosenberg, D. & Frank, L. (2012). The Role of the Built Environment in Healthy Aging: Community Design, Physical Activity, and Health among Older Adults. *Journal of Planning Literature*, 27 (1), 43-60.
 Loo-See Beh & Yoong, Folk Jee (2012). Financial Literacy Key to Retirement Planning in Malaysia. *Journal of Management and Sustainability*, 2(1), 1-12.
 Michael, B. & Anupam, N. (2012). Household attributes and the future demand for retirement housing. *Real Estate and Planning*, 1-26
 Miskovski, K., Chenoweth, L. & Moore, B. (2015) *Living with Dementia in Retirement*

- Villages*, Alzheimer's Australia NSW
Discussion Paper 13, August 2015.
- National Seniors Productive Ageing Center
(2013). Relocation to a Retirement
Village: Who Considers Relocation and
What are People Looking for?
- Netten, A., Darton, R., Baumker, T. &
Callaghan, L. (2011). Improving Housing
with Care Choices for Older People: An
Evaluation of Extra Care Housing,
Personal Social Services Research Unit,
University of Kent, Canterbury.
- NSW Fair Trading (2011). Retirement village
living: An overview of the NSW
retirement village laws, Parramatta NSW
2150.
- Parliamentary Library Research Service
(2012). Retirement Villages Amendment
(Information Disclosure) Bill 2012.
Victorian Parliament: Australia
- Saville-Smith, B. J. (2011). Retirement
Villages Act 2003: Monitoring Project
Residents' Perspective. Retirement
Commission